

SCOTTISH SCHOOLS SCIENCE

EQUIPMENT RESEARCH

CENTRE

Bulletin No. 120.

April, 1980.

Contents

Introduction	- Planning Committee reorganisation	Page 1.
	- SSSERC subscriptions	1.
Biology Notes	- bioluminescence	2.
Physics Notes	- demonstration digital display	5.
In the Workshop	- " " "	6.
	- modified deflagrating spoons	8.
Trade News		9.
Address List		10.
Index, Nos. 110-119		11.

Introduction

Some time ago our Governing Body, after consideration of a report by a subcommittee established to review the constitution and remit of our Development Committee, resolved that the remit should be changed to one which sifts through ideas, selects priorities and draws up a programme of work. The committee, which is to be re-named the Planning Committee, should consider requests and suggestions from a wide variety of sources and establish the priority list of work for the following year. In particular, the Planning Committee will undertake the selection of expensive items of equipment for test, research into the design of equipment for curriculum development, the safety of laboratory equipment and experimental methods in science, the publicity and information programme of the Centre, and review on a yearly basis the functions of SSSERC.

The Planning Committee will have a membership consisting of: a member of the Central Committee on Science, an H.M.I., a science adviser, a school technician, six practising teachers, and the director of the Centre. In addition the Planning Committee can co-opt up to three members for their individual expertise. These appointments are now being made and it is expected that the Planning Committee will start to function in May or June.

These changes have their obverse side, and it is with real regret that SSSERC says goodbye to the members, past and present, of its Development Committee. They have always been very helpful, and their help was always appreciated, even if we did not say so as often as we might have done. It would be a long list if we were to mention them all by name, and also somewhat pointless as many have gone to work outside the science education field and will not receive this bulletin. We need no reasons, however, for mentioning one of them. Emeritus Professor W.H.J. Childs of Heriot Watt University has helped and supported the ideal of SSSERC since before the existence of SSSERC itself. He has been the Chairman of the Development Committee since its inception, so that this was in no sense a purely honorary post. Often in the heat of debate his quiet yet incisive comment would bring us back on the rails, even when we had not realised there were any rails there. While we wish him a happy retirement, we hope he will often come back to see us, for he will always be sure of a welcome.

* * * * *

Inflation affects us all, and much time has been spent by the Governing Body in trying to ensure that financial resources are available to maintain the standard of service at the Centre. Although we are pleased to be able to tell you that when inflation has been accounted for, the SSSERC service costs less now than it did in 1968, this does not alter the fact that the SSSERC budget is increasing yearly by 10-15%. These increases are met by increasing the yearly contribution from regional authorities, and since no formal arrangement exists for the private sector of education, these tend to be left behind. This will please the private and the grant aided schools, since they get the same standard of service, but when the jump does come it tends to be a big one.

At their last meeting the Governing Body brought into effect a

three tier system of subscriptions. For private and grant aided schools in Scotland, the annual subscription will rise to £40. For schools and other institutions in the rest of the U.K. the subscription will be £20; this figure will also apply to manufacturers. For subscribers outside the U.K., the amount will be £10. These increases will come into effect at the start of the 1980/81 school session.

Biology Notes

Bioluminescence, the production of light by living organisms, is a fascinating topic. A very wide range of organisms are capable of bioluminescence but only a handful of species have been investigated in great depth (1). However in some of these the light producing reactions are now fairly well understood. Nearly all of the systems studied so far involve enzymes called luciferases, but the reactions catalysed vary from species to species. For example firefly luciferase catalyses the reaction

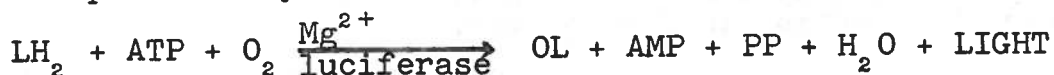

where LH_2 = luciferin (reduced form), OL = luciferin (oxidised form)

AMP = adenosine monophosphate, PP = inorganic pyrophosphate. More details of this reaction are given by Britton (2).

In bacteria the light producing reaction is slightly different. Bacterial luciferase has been isolated but no simple bacterial luciferin has been found. Photobacterium fischeri and P. phosphoreum, two bioluminescent, marine species, produce light in the presence of a straight chain aldehyde ($\text{R}\cdot\text{CHO}$) and dihydroflavin mononucleotide (FMNH_2):

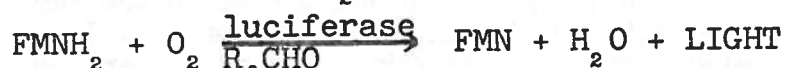

Applications of this reaction have included use in bacterial counting and pollution detection (2). The firefly luciferase system is sufficiently well understood for it to be used in a routine method for the assay of ATP.

Because bioluminescence is such an interesting topic, illustrative of a number of aspects of biochemistry, it was included in the syllabus for the Certificate of Sixth Year Studies in Biology (Unit 4, 'Cell Energetics'). However we have found experimental work with Photobacterium phosphoreum so rewarding that we can see exciting possibilities for work further down the school. Because the light producing reaction is enzyme controlled and requires oxygen a number of important biological principles may be illustrated with dramatic effect.

Cultures of P. phosphoreum are available from the National Collection of Marine Bacteria at Torry Research station. Culture number 844 should be requested as this is a particularly 'bright' strain. A culture costs £5 plus 17p postage. This may sound a little expensive but compared with the price of firefly material it represents a bargain. In our experience the results obtained are well worth the outlay.

On receipt, the culture was subcultured into a sea water broth and onto an agar slope to form stock cultures. Pure culture techniques were used for the initial inoculation and growth of the main cultures but it was not necessary to use sterile containers for the actual experiments if the cultures used were discarded immediately afterwards.

Recipes for media will be sent with the culture if specifically requested. We used a slight modification of the NCMB recipe, a broth described by Brisbane (1).

Aged, filtered sea water	75% v/v
Distilled water	25% "
Bacteriological peptone	0.3% w/v
Yeast extract	0.3% "
Glycerol	0.2% v/v

The sea water should be collected some three weeks before it is needed and 'aged' by standing it in a dark cupboard until it is required. Alternatively artificial sea water may be used in place of 'aged' natural sea water. The pH of the medium should be adjusted to 7 using 1M sodium hydroxide. If a solid medium is required 1.5% w/v agar can be added. Media should be autoclaved before use.

Experiments

To observe the results of most of the experiments described below, a blacked out room is needed. Initially the amount of light produced may seem very small, but as the observer's eyes adjust and his pupils dilate, the emission will become more and more obvious. The emission takes the form of a greenish glow which with an active culture will illuminate the culture vessel and some of the surrounding surfaces.

(a) Light emission as an indicator of growth. If 1ml of an actively growing culture is added to 100ml of broth in a 250ml flask and incubated at 20°C, light emission will reach a maximum after 12-15 hours and then fall off steadily. At sixth year level standard counting methods or turbidimetric measurements could be used to confirm that maximum cell density occurs at about the same time as maximum light production. If a number of flasks of broth are inoculated at intervals, cultures of different ages may be viewed simultaneously and the rise and fall of emission with age observed.

(b) Requirement for oxygen. When a relatively large volume of actively growing culture is allowed to stand in a closed, narrow necked vessel (e.g. 300ml in a stoppered 500ml conical flask), light emission becomes restricted to the surface layer. Here at the interface oxygen in sufficient quantity reaches the bacteria by diffusion. If the culture is gently swirled the emitting layer will grow. On inverting the flask oxygen spreads through the whole culture which then gives out light. The same effect, of increased emission with increased oxygen supply, can be produced by aerating a culture using an aquarium pump.

A more sophisticated procedure can be used at sixth year level. 2ml of .001% w/v methylene blue is added to 40ml of actively growing culture in a boiling tube. The tube is shaken to disperse the methylene blue throughout the culture which is then allowed to stand. After a while the dye at the bottom of the tube becomes reduced to the colourless form. If the lights are then switched off it can be seen that the culture produces no light where the methylene blue is reduced. If the tube is gently swirled and periodically illuminated

by a torch it can be seen that light emission occurs only in the blue areas where the dye is oxidised. This strengthens the idea that the light producing reaction is aerobic since light emission only occurs where the dye is in the oxidised state.

If a really spectacular demonstration of increased emission with aeration is required then a large volume, say 500-1000ml, of broth culture in a stoppered vessel such as a measuring jar should do the trick.

(c) The effect of temperature. As with other enzymes, luciferase activity is affected by temperature. If 20ml or so of active culture is placed in a boiling tube and this is placed in iced water, light emission ceases after a few minutes. If the tube is then transferred to warm water, light emission is resumed. Other possibilities, which we have yet to trial, would be arranging tubes of culture along a thermal gradient and using cessation of light emission to demonstrate the thermal death point. Other factors affecting the rate of enzyme controlled reactions such as pH could be investigated in a similar way.

(d) Antibiotic action. It is fairly obvious that since growth and light production are coupled it should be possible to monitor antibiotic action using light production. In our experiments the effects of a number of antibiotics were studied by using multodisks.

Two sea water nutrient agar plates were prepared. 1ml of a 24 hour broth culture was added to each plate and spread over the surface by swirling. The excess was then tipped off and the plate allowed to drain for about 10 minutes. An Oxoid multodisk was placed on the surface of one plate and the other plate served as a control. The plates were set up at 4pm, incubated overnight at 20°C and examined in the dark at 9am the next morning. Both plates were emitting light but there were obvious dark patches in the areas occupied by certain of the antibiotic discs. In this experiment the bacterium was found to be sensitive to ampicillin, penicillin G, cloxacillin and to some extent to tetracycline. There was little or no sensitivity to chloramphenicol, erythromycin, novobiocin or streptomycin. It is important to set up these experiments so that the resultant pattern of light production can be examined after 15 to 18 hours. After this time light emission from the plates may fall off appreciably.

(e) 'Autophotography' of the bacterium. This is a particularly fascinating aspect of this work. Indeed it was the great interest shown by Scottish teachers in our own photographs of cultures of P. phosphoreum which prompted the writing of this article.

With a fast black and white film pictures can be taken of the cultures with no other source of illumination than the light given off by the bacterium itself. An active broth culture suitable for photography can be obtained by sub-culturing and incubating at 20°C for about 18 hours. Our photographs were taken at 9 to 10am using 100ml of broth culture which had been inoculated with 1 or 2ml of actively luminescing culture late in the previous afternoon.

The culture vessel used was a graduated 250ml flask with a stopper of non-absorbent cotton wool. A 35mm SLR camera loaded with Ilford HP4 (400-650ASA) was used at distances of up to 40cm. Exposure times of 2 to 3 minutes at f2.8 were required so a tripod and cable release proved useful. The room was completely blacked out but sufficient light was released by the bacterium for the photographs to show clearly the graduation marks on the flask and the outlines of the cotton wool stopper.

We also attempted colour photography of the antibiotic treated plates described under (d) above. However with 100ASA colour film even exposures as long as 4 minutes at f2.8 proved ineffective. Successful black and white photographs of similar plates have been taken using 125ASA film at f2.0 for 100 seconds (1).

Although, as far as we are aware, P. phosphoreum is non-pathogenic and serious contamination of media unlikely because of their salinity, this does not remove the necessity for sound technique. The reader's attention is drawn to the notes for guidance in references (3) and (4).

Acknowledgement

Whilst all the work with Photobacterium phosphoreum actually described here has been tried out in the Centre, most of the experiments are not original. They were based on work using Achromobacter (Photobacterium) fischeri (sic) reported in the South Australia Science Teachers' Association Journal (1).

References

1. Brisbane, P.G., SASTA Journal, July 1973, p.6-9.
2. Britton, G.C., S.S.R., 1975, 56, 196, p.541-545.
3. The use of micro-organisms in schools, DES Education Pamphlet No. 61, 1977, HMSO.
4. SSSERC Bulletin 98.

Physics Notes

For some time we have sought a digital display which could be driven from t.t.l. and which would be large enough to be seen from the rear of a classroom. The 'jumbo' size of l.e.d. display, DL747, has characters 15mm high which is hardly large enough for demonstration use, and besides the l.e.d. type of illumination cannot compete with the full sunlight which is so often the norm in modern school labs. Unilab, in their display unit, use an array of 14 low voltage lamps which will not fit the t.t.l. 7-segment system without modification, because the lamps at each of the four corners are common to both horizontal and vertical bars of the character.

What we chose was the 12V, 3W festoon lamp bulb, obtainable from Halfords or garages, as they are commonly used as interior lights in cars. Each lamp is fixed to a hardboard panel by a single Terry clip grasping it around the middle, and wires soldered to each end, and passing through small holes in the hardboard are used to make the electrical connection. Although this means more trouble for the technician when a lamp burns out, the absence of a holder means that the lamps can be spaced closer which helps to give a continuous appearance to the displayed number instead of a few disconnected lines.

The power supply to the display is a problem. A four digit display will need 28 lamps, and 12V, 7A power. There is also variation of $3\frac{1}{2}$ times between the lightest load, when showing figure 1, and the heaviest which is figure 8. Fortunately, educational low voltage power supplies have been built with this type of provision, so

that the school already has the most expensive part of the construction. Thyristors or triacs are the obvious method of controlling the lamps, and here we have used 2N4196 because we have a stock of over 200. This thyristor has a T064 outline for mounting on a heat sink, which is not necessary in this application, and it could be bolted to hard-board, perspex or any other type of mount. An alternative which we have tested is 2N5060, a thyristor rated at 30V, 0.8A. This has a T092 outline and is more convenient for soldering directly to p.c.b. It is also more expensive, costing 34p from Technomatic.

The circuit for driving a lamp is shown below. The input is active-low, such as will be got from a SN7447, for example. As discussed above, this circuit will require to be duplicated seven times for a single digit, or 28 times for a four digit display. The approximate cost for a single digit is:

Festoon lamps	7	Halfords	£1.82
Thyristor 2N4196	7	SSSERC	0.35
Transistor BC108	7	Bipak	0.42
Resistors, various	21	RS Components	0.80
			£3.39

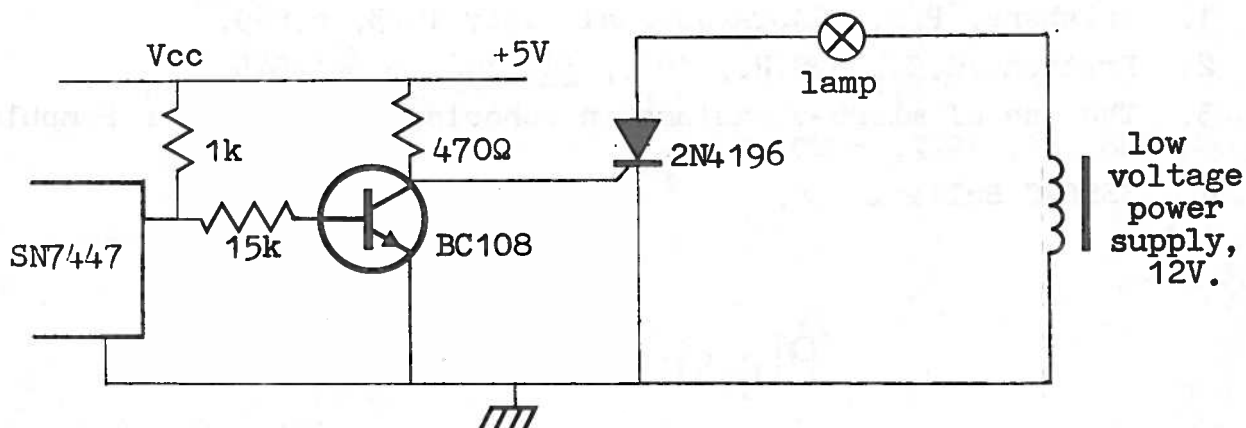

Each BC108 driver requires about 10mA current, so that a four digit display will require about 280mA at 5V. This is in addition to the current required by the t.t.l. circuitry. If the 2N5060 thyristor is used, mounted on p.c.b. then we recommend at least three copper strips of the p.c.b. to be used for the ground connection to the thyristor cathodes, as this has to carry the relatively heavy current to the lamps.

We have made a model which can be seen in the Centre of three digits and a timing circuit which counts at a speed of about one per second, so that visitors can judge whether the results are acceptable. In one region at least, that of safety, we think the circuit has an advantage over one or two circuits we have seen, for example for cricket score boards, which used main lamps, switches and relays.

In The Workshop

The display described in the physics notes section of the bulletin uses seven festoon lamps to make a single digit. These are in the form of two squares, one above the other, to form a

figure 8, and in our model the centre lines denoting the lamps were on squares of 40mm side. This means that the ends of the lamps are within a few mm of each other. A single Terry clip bolted by a 8BA nut and bolt keeps each one in place in a hardboard base. The lamps are covered at the front with formica, in which we cut slots 30 x 3mm wide, centring these on the centre lines already stated. The formica is covered in a sheet of Cobex Clearlite, a translucent material from the Clearvue Projection Co. used for projection screens, and then a green filter. The Clearlite can be omitted but the light is then not diffused, and the lamp filaments are visible through the display.

One problem in making the display is to prevent light from one segment spilling over into segments which are unlit, which may make it difficult for the viewer to decide which segments are on and which are off. To block the segments from each other we made two square wooden blocks from plywood, 20 x 20 x 17mm high to cover the centres of the square, and lined the sides with 17mm wide strip in black polythene, making the sides oversize so that they splay into a V at each corner. The notch of the V then prevents light from one lamp getting to the neighbouring lamp at the corner. The box holding the cover in place should also be 17mm high so that the top of the square blocks are in contact with the formica and no stray light can get in across the top.

The actual filament of each lamp is only about 10mm long, so that there is difficulty in making this seem like a lighted strip 40mm long. Diffusion with the Clearlite helps in this respect, as does the effort to keep stray light to a minimum. While the display is not very effective close at hand, we think that pupils should have no difficulty in recognising the figures from a distance of 3m or more.

Dimensions in mm
actual size

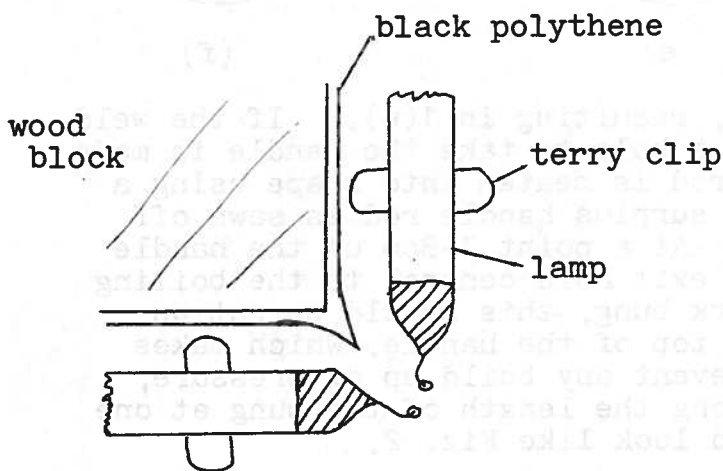

Fig. 2.

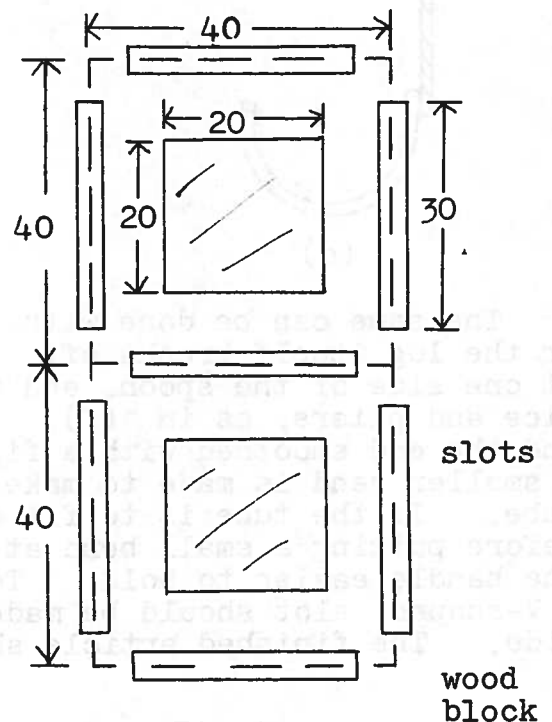

Fig. 1.

Fig. 1. Location of slots for a digit. Fig. 2. Corner detail.

* * * * *

It was pointed out to us by Currie High School that many schools have drawers full of deflagrating spoons as a relic of the teacher demonstration age and that a small modification of these enables them to fit into a boiling tube (145mm x 25mm). The added bonus is that such modified spoons are superior to the 'Nuffield' combustion spoons which only have a very shallow cup; burning materials stay in these modified spoons much better.

The spoons have a shelf or lug at one side for the attachment of the handle. Sometimes the handle is bent and welded to the lug as in Fig. 1(a), sometimes it is crimped through a hole in the lug as in 1(b). The modification of 1(a) consists of holding the spoon in the jaws of the vice as in 1(c) and bending the lug until it is upright 1(d).

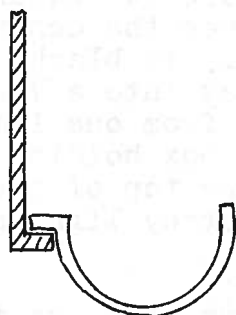
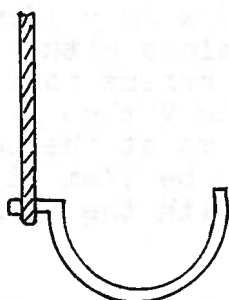
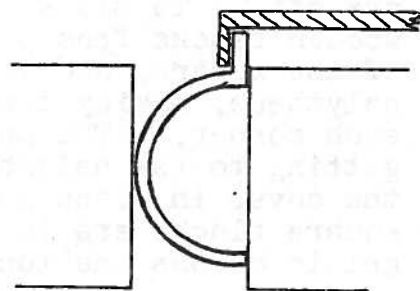

Fig.1.(a)



(b)



(c)

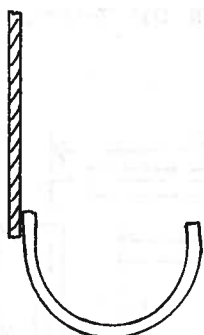

(d)

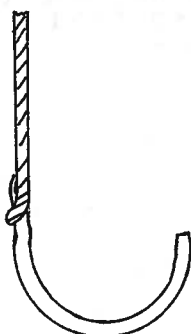

(e)

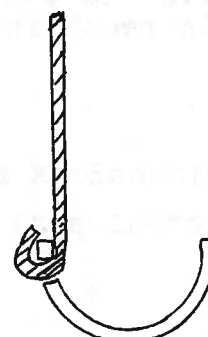

(f)

The same can be done with 1(c), resulting in 1(e). If the weld, or the lug itself breaks off, then a hole to take the handle is made at one side of the spoon, and the rod is beaten into shape using a vice and pliers, as in 1(f). The surplus handle rod is sawn off and the end smoothed with a file. At a point 7-8cm up the handle a smaller bend is made to make the exit hole central to the boiling tube. If the tube is to fit a cork bung, this should be put on before putting a small bend at the top of the handle, which makes the handle easier to hold. To prevent any build up of pressure, a V-shaped slot should be made along the length of the bung at one side. The finished article should look like Fig. 2.

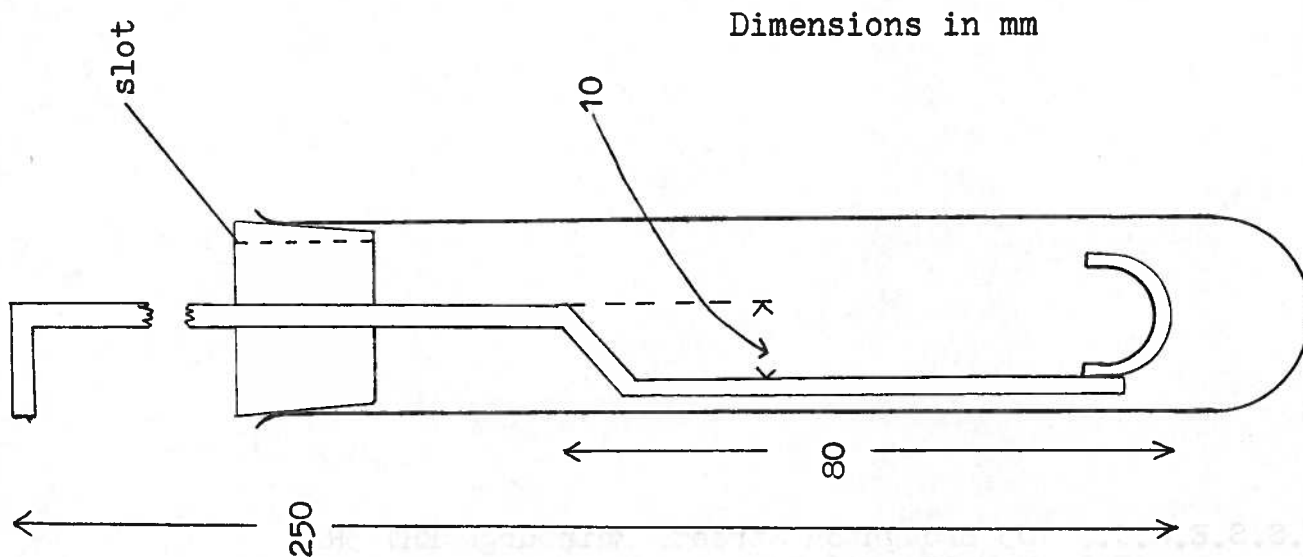

Fig.2.

Trade News

In Bulletins 110 and 112 the performance testing of autoclaves and pressure cookers was discussed at some length. With the aim of making a biological test more straightforward and convenient, Gerrard are now offering a steriliser testing kit ZEA-870-P. This contains paper strips impregnated with spores of Bacillus stearothermophilus, two tubes of tryptone soya broth and full instructions. At £1.40 a set it is probably too expensive for routine use but would provide a useful occasional check against cheaper 'non-biological' methods.

Philip Harris Biological have recently launched a resource pack - 'Safety Matters' Cat. No. A39000/8. Aiming to make safety training an integral part of a science course the pack contains items to support safety training throughout the year. Included in the contents are filmstrip/slide material, games, crosswords, pupil worksheets, tests, a cassette tape and a teachers' guide. On many of these items copyright has been waived, which may sweeten the pill for anyone considering buying a pack at the price of £25.

Gauntlet gloves of heat resistant leather with welted seams and lined for extra protection are available from Parabest, Cat No. 6080/34 at £2.52. Gauntlets giving protection against oil and heat, Cat. No. OH1, cost £3.71.

The following reports have been received from CLEAPSE and can be borrowed by writing to the Director of SSSERC.

- L59c Regulated low voltage power supplies
- I4a Electronic top pan balances.

S.S.S.E.R.C., 103 Broughton Street, Edinburgh EH1 3RZ
Tel. No. 031 556 2184.

Bipak Semi-conductors Ltd, P.O. Box 6, Ware, Herts.

CLEAPSE Development Group, Brunel University, Kingston Lane,
Uxbridge, Middlesex.

Clearvue Projection Co. Ltd., 92 Stroud Green Road, London N4 3EN.

Gerrard Biological Centre, Worthing Road, East Preston, Sussex
BN16 1AS.

Philip Harris Biological Ltd., Oldmixon, Weston Super Mare,
Avon BS24 9BJ.

National Collection of Marine Bacteria, Torry Research Station,
135 Abbey Road, Aberdeen AB9 8DG.

Parabest Ltd., Lutterworth, Leics LE17 4DU.

R.S. Components Ltd., P.O. Box 427, 13-17 Epworth Street,
London EC2P 2HA.

Technomatic Ltd., 17 Burnley Road, London NW10 1ED.

Bulletin Index Nos. 110 - 119

Acetanilide hazard	114, 1
Agricultural science equipment list	113, 9
Ammeter, moving coil model	114, 10
Autoclaves, performance testing of	110, 1
Balances, electronic, summary	116, 6
Biological stains hazard	119, 2
Blood sampling procedure	115, 4
B.R. stations handling livestock	114, 2
Car ignition coil sparking generator	118, 2
Carcinogenic hazards	117, 1
Centrifuge hazard	116, 11
Centrifuges, test summary	115, 11
Circular motion experiments using data memory	118, 4
Cleapse reports	117, 7
Combustion calorimeters	114, 3, 8
Combustion calorimeter hazards	113, 2
Commutator-less d.c. motor	111, 7
Cost index	114, 1; 117, 1
Double deck bus stability model	111, 8
Electrical safety testing	118, 1
Electronic balances summary	116, 6
Equipment list, agricultural science	113, 9
Equipment list, integrated science	111, 1
Flammables storage in schools	111, 3
Frequency meter, conversion to scaler	111, 5
Frequency meter from scaler	115, 8
Gating unit for scaler/timers	112, 11
Hazard, centrifuge cover	116, 11
Hazard, immersion heater	114, 1
Hazard, microscope lamp	117, 10
Hazard, overhead projectors	116, 11
Hazardous chemicals manual	110, 1
Hazards, biological stains	119, 2
Hazards, carcinogenic	117, 1
Hazards, combustion calorimeters	113, 2
Hydrogen peroxide dilution	119, 6
Immersion heater hazard	114, 1
Integrated science equipment list	111, 1
Ion exchange resin, regeneration	116, 8; 110, 5

Leaf litter, examination of	116,4
Livestock handling by B.R.	114,2
L.T. power supplies, test summary	118,11
Micro-electronics in schools	112,1
Microscope illumination, factors affecting	113,4
Microscope lamp, safety modification	117,10
Motor, commutator-less	111,7
Moving coil movement model	114,10
Overhead projector, lamp bulb life	110,9; 118,9
Overhead projectors fire hazard	116,11
Oxides, reduction using natural gas	115,1
Oxygen electrodes, WPA	117,8
Oxygen meters, d-i-y circuits	110,2
N-phenylethanamide hazard	114,1
pH meters, temperature compensation	119,4
Poisons, storage in schools	112,3
Pressure cookers, performance testing	110,1
Pressure cookers used for sterilisation	112,6
Pulse beat indicator	111,5
Quiz game control unit	119,7
Reducing oxides using natural gas	115,1
Regenerating a mixed bed ion exchange resin	116,8; 110,5
Safety committees, SSSERC involvement	112,1
Scaler from frequency meter	111,5
Scaler/timer gating unit	112,11
Scaler to frequency meter conversion	115,8
Sparking generator, using car ignition coil	118,2
Stability of double deck bus model	111,8
Sterilisation using pressure cookers	112,6
Storage of flammables in schools	111,3
Storage of poisons in schools	112,3
Surplus equipment	110,8; 113,9; 116,9
Surplus equipment, summary of operation	116,1
Technician workshops	119,1
Temperature compensation for pH meters	119,4
Test summary, centrifuges	115,11
Test summary, L.T. power supplies	118,11
Voltage controlled oscillator	115,7
WPA apparatus design competition	118,2